

DESCRIPTION

The **DTU belt weighfeeder** is a universal solution to the problem of dosing bulk material with flow up to 40 000 [l/h]. Thanks to hygienic construction that enables easy disassembly and cleaning of certain elements, the weighfeeder is especially useful in food industry.

Flow control is done by changing the belt traverse velocity. The **gravity take-up** extends the belt's lifespan and improves measurement accuracy, while **scrapers** (internal and external) clean the belt from material residue. The DTU weighfeeder is also equipped with **assembly that prevents belt deviation** and **system that allows to quickly change the belt** without need to change the tension degree.

Depending on utilised control system, the device allows feeding in constant or non-constant (batch) mode. It can also be used only to measure the amount of flowing material.

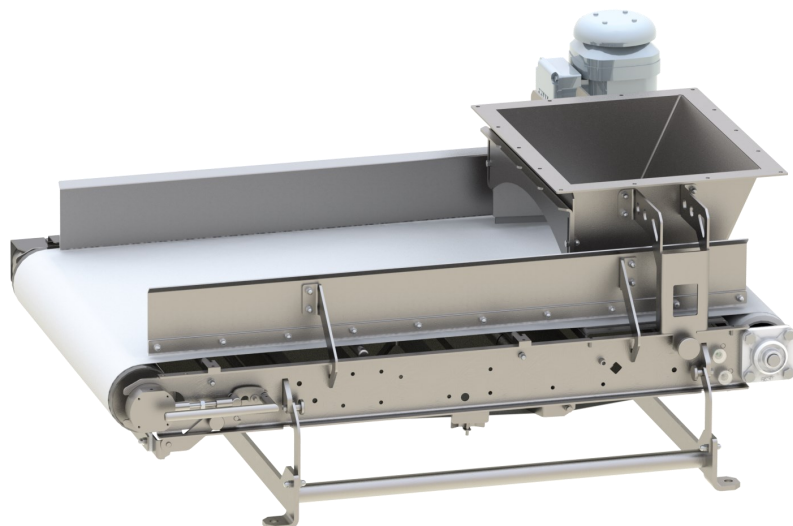

SPECIFICATION

- Feeding accuracy: $\pm 0,5\%$ of set value
- Belt width: **300** or **600** [mm]
- Work at ambient temperature between **0** and **50 °C**
- Belt made of **polyurethane** has the FDA certificate
- 3x400 [V] AC motor with power **0,18**, **0,25** or **0,37** [kW] (depending on gear ratio)
- Belt traverse velocity control is done using an inverter.



FEED RATES

- **20÷20 000** [l/h] (belt width: 300 [mm])
- **80÷40 000** [l/h] (belt width: 600 [mm])
- Turndown ratio: **1:10**
- Change of shear gate level in inlet hopper increases the turndown ratio.



MEASUREMENT SYSTEM

- The scale is based on a **single-point C3-class load cell** made of stainless steel or aluminium, with IP66 (optionally IP68) protection class.
- **Belt speed sensor** (IP67 protection class, stainless steel) located at the driven pulley.



CONTROL SYSTEMS

Material flow measurement:

- 1020
- SGM800
- FLEX 2100/FLEX

Continuous and **batch** feeding:

- FLEX 2100/FLEX



CONSTRUCTION

- The scale is made of **304 stainless steel**.
- The belt scraper inserts are made of **PE UHMW** (FDA certificate).
- Drive pulley rubberized (FDA certificate)



OPTIONS

- Manufactured of **316L stainless steel**
- Vibrating inlet
- Ability to control the prefeeder
- Belt deviation control
- Belt slip control
- Execution for **Ex-zones**
- Aseptic motor
- Belt made for materials with temperature up to **110 °C**
- Load cell with IP68 protection class
- Turndown ratio: **1:20** or **1:50**
- Dust-proof housing

DIMENSIONS

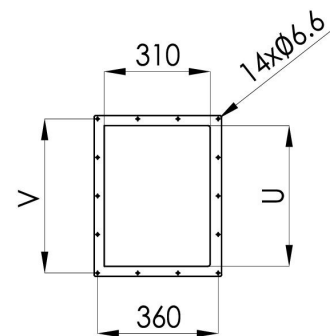
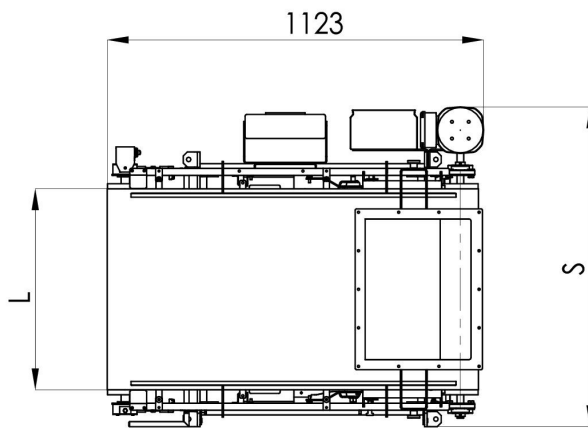
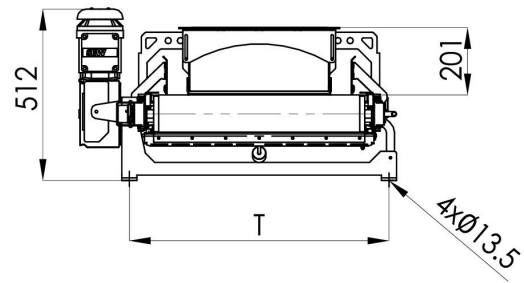
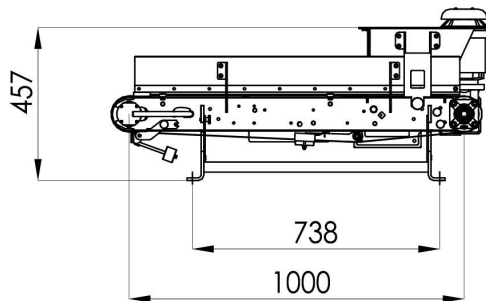
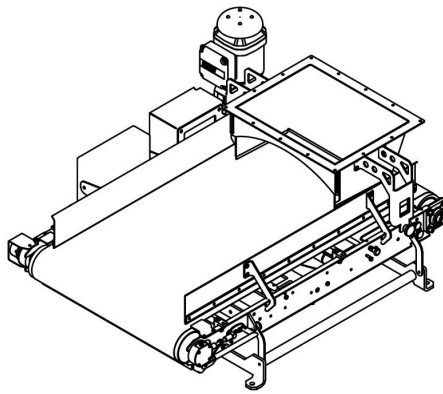

Belt width L	S	T	U	V
300	655	475	150	190
600	955	775	450	490

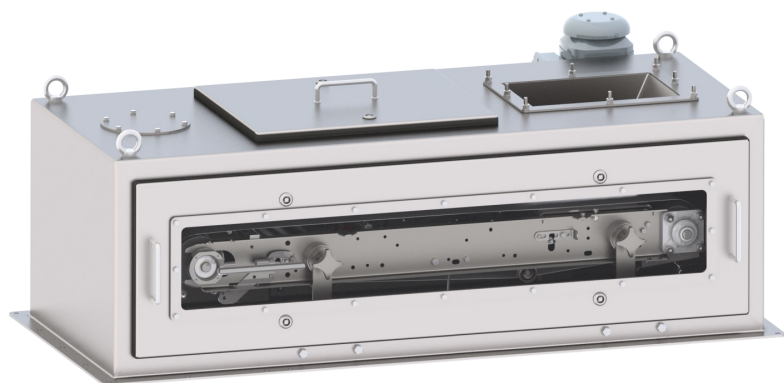

DESCRIPTION

The **DTU belt weighfeeder** is a universal solution to the problem of dosing bulk material with flow up to 40 000 [l/h]. Thanks to hygienic construction that enables easy disassembly and cleaning of certain elements, the weighfeeder is especially useful in food industry.

Flow control is done by changing the belt traverse velocity. The **gravity take-up** extends the belt's lifespan and improves measurement accuracy, while **scrapers** (internal and external) clean the belt from material residue. The DTU weighfeeder is also equipped with **assembly that prevents belt deviation** and **system that allows to quickly change the belt** without need to change the tension degree.

Depending on utilised control system, the device allows feeding in continuous or non-continuous (batch) mode. It can also be used only to measure the amount of flowing material.

Dust-proof housing allows to connect a dust removal system. Removable side covers are equipped with inspection windows made of polycarbonate.

QUICK & EASY BELT CHANGE:

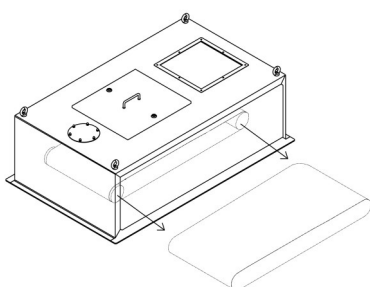

SPECIFICATION

- Feeding accuracy: $\pm 0,5\%$ of set value
- Belt width: **300** or **600 [mm]**
- Work at ambient temperature between **0** and **50 °C**
- Belt made of **polyurethane** has the FDA certificate
- 3x400 [V] AC motor with power **0,18**, **0,25** or **0,37 [kW]** (depending on gear ratio)
- Belt traverse velocity control is done using an inverter.



FEED RATES

- **20÷20 000 [l/h]** (belt width: 300 [mm])
- **80÷40 000 [l/h]** (belt width: 600 [mm])
- Turndown ratio: **1:10**
- Change of shear gate level in inlet hopper increases the turndown ratio.



MEASUREMENT SYS-

- The scale is based on a **single-point C3** -class **load cell** made of stainless steel or aluminium, with IP66 (optionally IP68) protection class.
- **Belt speed sensor** (IP67 protection class, stainless steel) located at the driven pulley.



CONTROL SYSTEMS

Material flow measurement:

- 1020
- SGM800
- FLEX 2100/FLEX

Continuous and **batch** feeding:

- FLEX 2100/FLEX



CONSTRUCTION

- The scale is made of **304 stainless steel**.
- The belt scraper inserts are made of **PE UHMW** (FDA certificate).
- Drive pulley rubberized (FDA certificate)



OPTIONS

- Manufactured of **316L stainless steel**
- Vibrating inlet
- Ability to control the prefeeder
- Belt deviation control
- Belt slip control
- Execution for Ex-zones
- Aseptic motor
- Belt made for materials with temperature up to **110 °C**
- Load cell with IP68 protection class
- Turndown ratio: **1:20** or **1:50**

DIMENSIONS

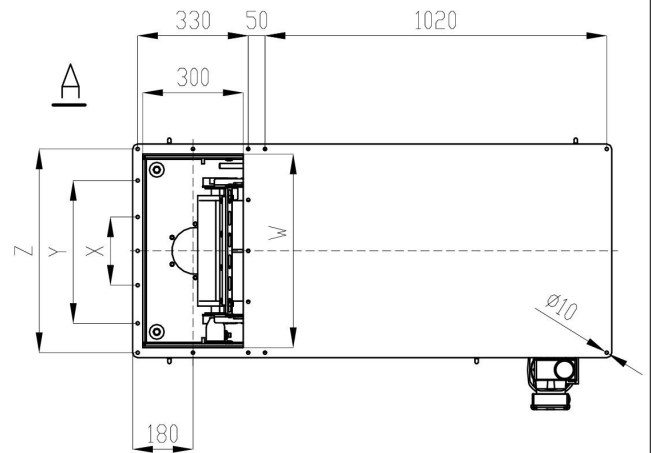
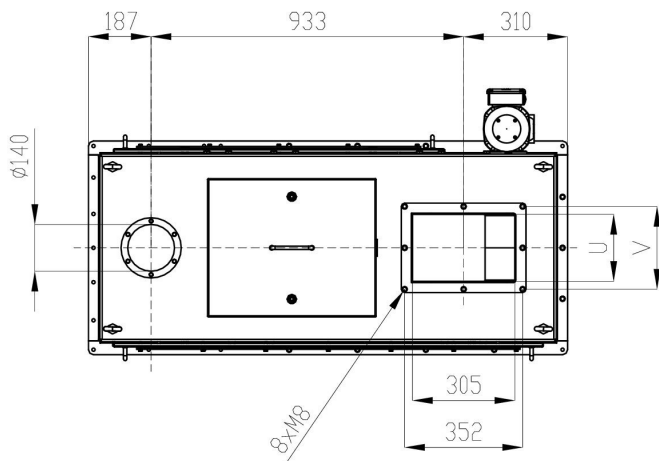
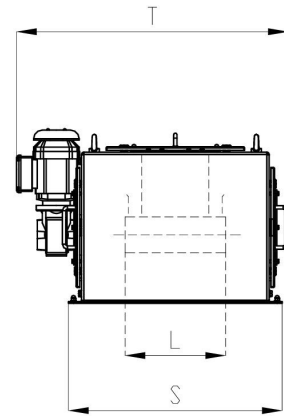
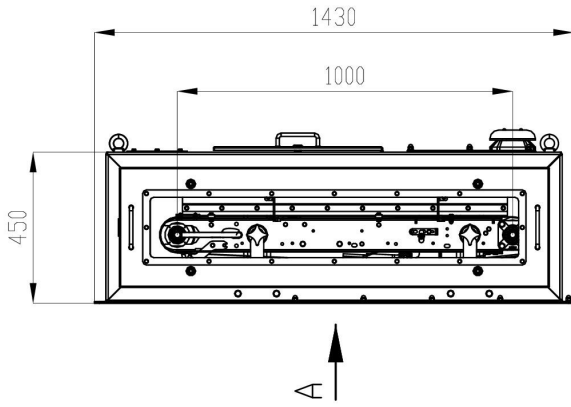
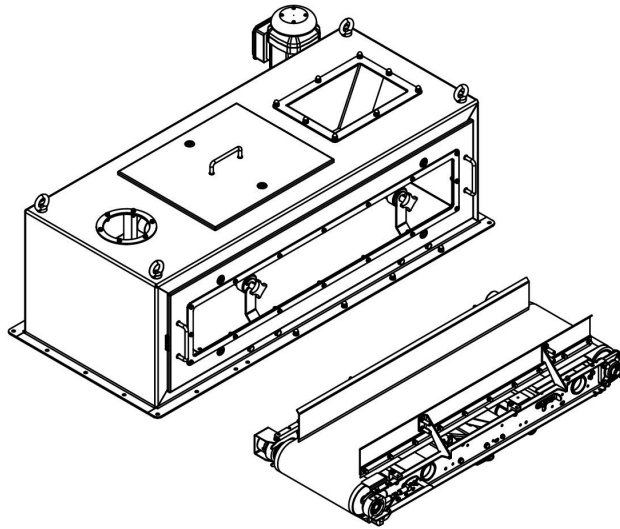

Belt width L	S	T	U	V	W	X	Y	Z
300	638	810	200	250	578	304	-	608
600	942	1110	500	550	882	304	608	912