

## DESCRIPTION

Our BIG-BAG filling systems enable a safe and efficient process of filling large-size bags with minimal staff involvement. The empty bag is attached to the four handles at the top corners of the frame. Then the bag inlet is pulled over the discharge pipe of the station. The tight connection between the bag and the pipe guarantees dust-free operation. The material can be fed into the bag by any conveyor. The BIG-BAG filling station can be equipped with a weighbridge, used to control the amount of material in the filled bag and the automation system that cuts off the flow of raw material after the bag is filled to the required weight. After filling the flexible bag and removing it from the steel frame, it is lifted with a forklift and transported to its destination. The construction is made of powder coated carbon steel. Optionally, it can be made of stainless steel 1.4301 (AISI304) or 1.4404 (AISI316L), thanks to which the station will be perfect for the food industry. The modular design allows the station to be adapted to the type of bag.

Each filling station is designed individually, on request and according to the customer's needs, for various sizes and types of bags.



### SPECIFICATION

- Construction height: **from 2000 to 3000 mm**
- Construction width x length: **1210 x 1445 mm**
- Maximum bag width: **1000 mm**
- Maximum bag height: **2000 mm**
- Construction weight: about **500 kg** (depending on the height of the construction)
- Maximum lifting capacity: **2000 kg**
- Filling of bags with a throat diameter: **350 - 500 mm**



### ADVANTAGES

- Application for a wide range of products
- Dust-free bag filling
- Reduction of losses related to the leakage of goods
- Operation of the device with minimal involvement of personnel
- Ease of use
- Possibility to adapt the station to the type of bag thanks to the modular design



### OPTIONS

- Equipment for forming bags before the filling process
- Weighbridge for controlling the amount of material in the filled bag
- Bag filling control system
- Design for the food industry with the use of FDA-compliant materials
- ATEX version



### INDUSTRY

- Chemical
- Fertilizing
- Food & feed
- Other similar industries



### TYPE OF MATERIAL

- Coarse-grained powders
- Fine powders
- Seeds
- Granules
- Various types of bulk materials



### EXECUTION

- Components in contact with material made of stainless steel
- The frame is made entirely of powder coated carbon steel
- Optionally made of stainless steel 1.4301 (AISI304) or 1.4404 (AISI316L)



### TIGHT AND DUST-FREE PROCESS



Our BIG-BAG filling systems enable a convenient and dust-free loading process. Thanks to the head with an inflatable seal, the connection between the bag and the station is tight. In addition, the construction can be connected to a dust extraction system.



### BAG FILLING PROCEDURE



1. Attach the empty BIG-BAG to the four handles in the upper corners of the frame.
2. Place the bag inlet on the discharge pipe of the station.
3. Press the button to activate the process of inflating the seal, which is to completely seal the connection between the bag and the station, thus ensuring dust-free operation.
4. With the next button, start the process of filling the BIG-BAG.
5. After obtaining the required weight, the system will cut off the supply of raw material and automatically unseal the connection, allowing you to easily remove the bag.



### ADAPTATION TO THE CUSTOMER'S NEEDS

Thanks to the modular construction, our BIG-BAG filling station can be easily adapted to the customer's needs - including to the dimensions of the filled bags. Optionally, the station may consist of a frame with the possibility of height adjustment.





### VARIOUS ADDITIONAL OPTIONS

BSA stations can be equipped with various additional options, such as equipment for pre-forming bags before starting the filling process, a vibrator for even filling the bag or a weighing system. Adding an intelligent control system results in a dust-free, automated and fully controlled BIG-BAG filling process.

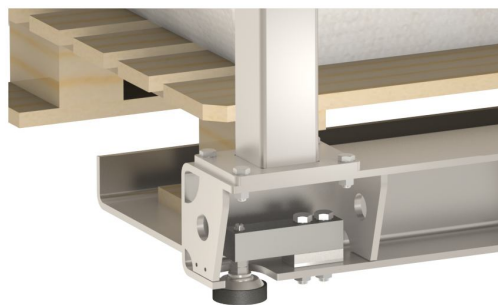

### INDIVIDUAL PROJECTS



Each filling station is designed individually, on request and according to the customer's needs, for various sizes and types of bags. On the above model, the station is made entirely of stainless steel 1.4404 (AISI316L), equipped with a weighing and control system. Additionally, at the customer's request, we have equipped our construction with a neodymium magnet, which prevents metal foreign bodies from entering the filled bag.